

9 Tonne Front Tip

KEY FEATURES & BENEFITS - MACH2290



The Thwaites 9 Tonne Front Tip, Stage V dumper is manufactured with contractors and hirers in mind – ensuring operator safety, reducing risk on site, and improving performance. Front Tip dumpers allow the machine to be easily and safely unloaded, with a straightforward tipping action that places the full bucket of spoil exactly where it is required.

Powered by a 3.6L Deutz turbo diesel engine fitted with a DPF to comply with EU stage V emission regulations, you benefit from 55.4 kW peak power, 405 Nm of torque and no AdBlue requirement.

Thwaites 9 Tonne machines are available in a range of further configurations to suit your needs:

- › Front Tip with Cab
- › Power Swivel

A Spring Activated Hydraulic Release (SAHR) Handbrake, 5" screen displaying 150° around machine visibility, hi-vis steps, LED road lights and twin LED beacons are available across the 9 Tonne range.

Safe, compliant and competitive.



Thwaites

Thwaites Ltd, Leamington Spa,
Warwickshire, CV32 7NQ, England
Tel +44 (0)1926 422471

www.thwaitesdumpers.co.uk



Snap this QR code
from your smart
phone for more
information



GET THE JOB DONE.

9 Tonne Front Tip

DIMENSIONS & SPECIFICATIONS - MACH2290

(mm)

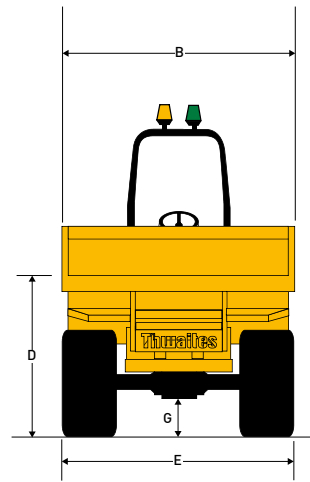
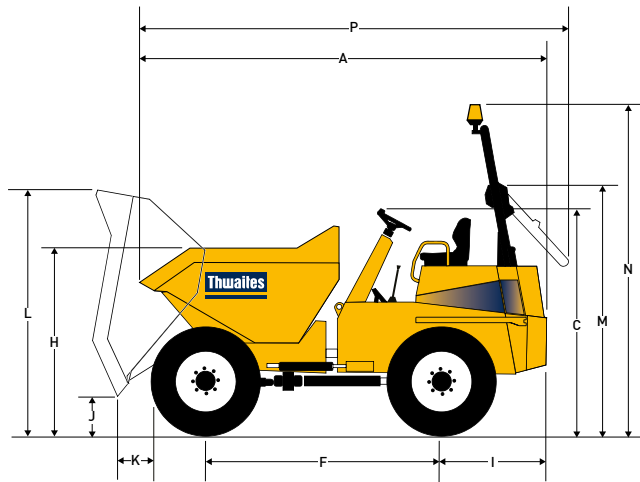

A	4670	N	3530
B	2485	P	5014
C	2440		
D	1740		
E	2444		
F	2615		
G	447		
H	1975		
I	1255		
J	436		
K	642		
L	2840		
M	2555		

Weight	Unladen	
	Shipping	4820kg
	Shipping	4696 kg

Capacities	Max safe load	
	Heaped	9000 kg
	Struck	4600 litres
	Water	3830 litres
		2155 litres

Engine

- › Deutz TCD 3.6 L4, water-cooled, 4-cylinder, charged air cooled turbo, fuel injected diesel and after treatment Diesel Particulate filter
- › Power 55.4 kW/ 74 bhp at 2200 rpm
- › Torque 405 Nm (299 lbf ft).

Noise Levels

- › Operator's ear 84 LpA / airborne level 101 LwA

Transmission

- › Torque converter four speed forward and reverse Powershuttle transmission, column mounted speed and directional control lever

Speeds	Forward and Reverse	
	1	4.4 km/h
2	7.1 km/h	(4.4 mph)
3	13.3 km/h	(8.3 mph)
4	24.3 km/h	(15 mph)

Brakes and Axles

- › Totally enclosed multiplate oil-immersed discs mounted on both axles & auto wear adjustment
- › Hand operated parking brake (SAHR)

Kinglink Chassis

- › Constructed from folded steel plate, with three point Kinglink giving articulation and oscillation for better stability, traction and safety on site

Skip

- › Hydraulically operated, 6 mm steel base plate
- › Skip mouth & sides reinforced with box sections

Seating & Controls

- › Adjustable suspension seat with high-vis seat belt
- › Clear operators display unit contains all warning lamps

Service Access

- › Lockable engine cover for ground level service points
- › Rear chassis panel can be hinged back on retainers

Electrics

- › Fuse & relay are housed on a central power distribution board
- › Main harness is fully enclosed in solid conduit and incorporates the engine diagnostic port

Steering and Hydraulics

- › Hydraulic power steering
- › Return line filtration for all services
- › Hydraulic test point fitted as standard

Tank Capacities	Fuel	
	Hydraulic	72 litres
		50 litres

Turning Circle	14m
----------------	-----

Standard Equipment

- › Camera and dashpanel monitor
- › LED beacons
- › Fan guard
- › Reverse alarm

Optional Equipment

- › Full LED road lighting incl. DRL (Daylight Running Lights)
- › Road mirrors
- › Wheel nut indicator
- › GPS speedometer

Thwaites

Thwaites Ltd. Leamington Spa,
Warwickshire, CV32 7NQ. England
Tel +44 (0)1926 422471

www.thwaitesdumpers.co.uk



Images are representative, but specific details or equipment may vary by country. We reserve the right to change any and all specifications without prior notice. 11/2021